

GIBSON valves

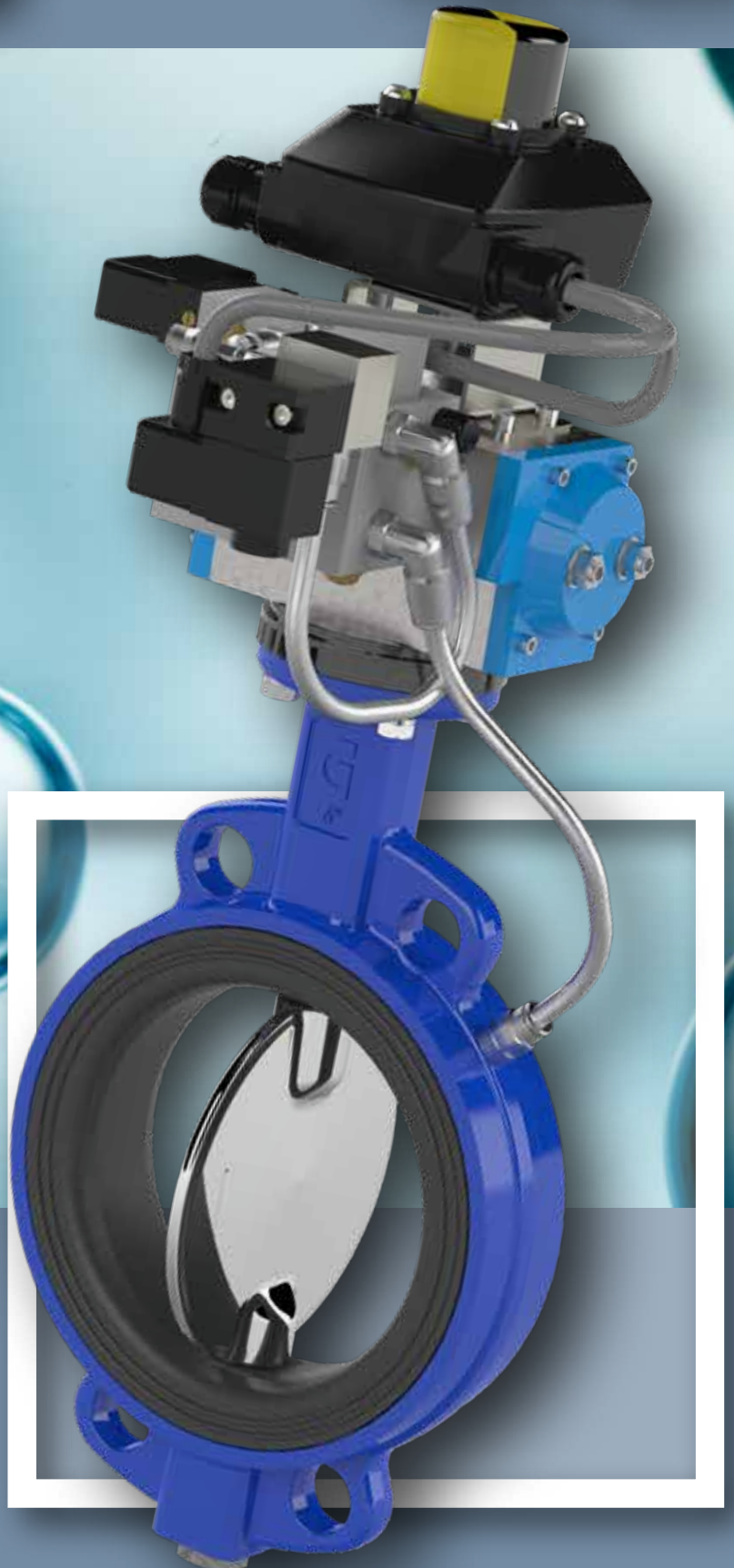

*rubber inflatable
seated valve
for abrasive application*

BUTTERFLY VALVES

DL Series

rubber inflatable seated valve for abrasive application



Pneumatic seated valves:

- created for bulk handling, in which the disc geometry is studied to permit low torque open/close.
- the lower friction disc/seat highly reduces heavily wear of the seats over time.
- longer lifetime of the valves and possibility to use of smaller actuators guarantee economical and space advantage
- easy installation with pre-packaged actuating solution

Operating principle:

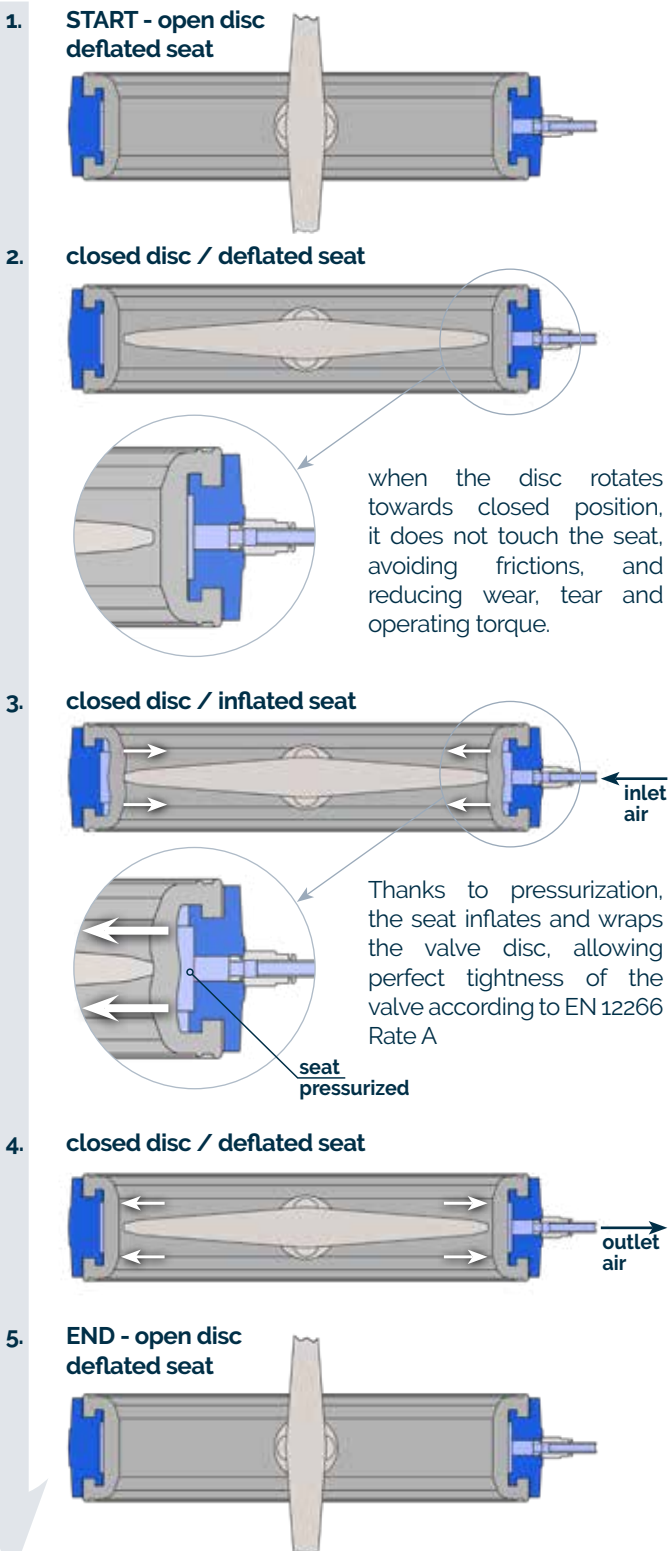

DN range	50+500
flange connection	PN 6/16 ANSI 150 JIS 10k
face to face	UNI EN 558-1 series 20

Different DN, flanges and design available on request

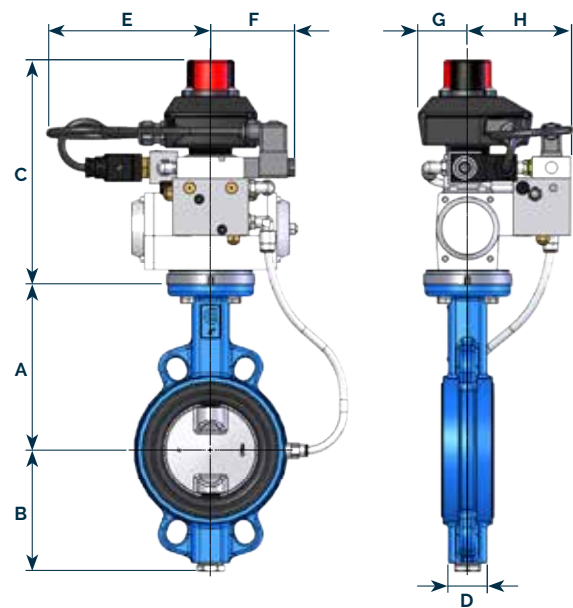

Dimensions

DN	A	B	C	D	E	F	G	H
050	138	81	237	46	175	92	52	108
065	144	98	237	46	175	92	52	108
080	158	110	237	46	175	92	52	108
100	173	128	237	52	175	92	52	108
125	186	140	237	56	175	92	52	108
150	202	155	237	56	175	92	52	108
200	240	190	258	60	175	97	64	114
250	270	220	278	68	175	124	64	123
300	300	247	309	78	175	134	65	125
350	330	280	314	78	175	134	65	125
400	355	305	314	102	175	134	65	123
450	400	343	330	112	175	134	65	130
500	422	366	300	127	175	134	65	130

Materials

SOFT SEATED BUTTERFLY VALVES

* On request can be supplied other materials

body*	
Ductile iron	EN-GJS 400-15 (GS400)
Aluminium	EN AB 46400
disc*	
Stainless steel	ASTM A351 CF8M (A316)
seat*	
NBR	nitrile rubber
MVQ	silicon rubber

BUTTERFLY VALVES

GHIBSON ITALIA

can now boast of more than 35 years of experience in manufacturing of industrial valves. We export our products all over the world always providing our customers the best assistance during all the phases: design, installation, maintenance.

HIGH PERFORMANCE

specifically designed for high demanding applications where the valve performance is critical. Available in different materials and ratings. The Fire safe version is Fire tested to API 607-6th ed.



PTFE SEATED

available in a wide range of materials combinations, and specifically designed for the chemical industry and heavy duty applications.

RUBBER SEATED

designed to fit in industrial applications from powder conveyance to marine and petrochemical requirements.



DAMPER VALVES

fully manufactured and designed according to customer requirements, mainly used with high temperature combined with low pressure applications.

CHECK VALVES



DISC TYPE

represent an extensive combination of solutions starting from low pressure design up to 160 Bars.

SWING TYPE

manufactured in many materials as well as pressure ratings and flange connections. Available for general purpose applications and also with spring loaded flap.



ACTUATORS & OPTIONS

Ghibson offers a wide range of actuators and accessories for valve automation. Normally supplied as part of complete assemblies with valves divided into the following types:

PNEUMATIC

Pneumatic actuators are based on rack and pinion technology, very compact and reliable.

Available with different options for any kind of industrial applications and ambient conditions. With all types of accessories. Standard/special executions.

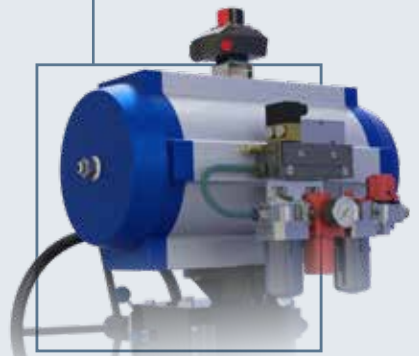

ELECTRIC

Electric actuators are available in different versions for ON-OFF and/or regulating applications.

Electric actuators also include ATEX versions as well a wide range of customizations.



HYDRAULIC

Ghibson's own manufactured hydraulic actuators (ARES series) are designed to fulfill the specific requirement in industrial applications: compact design and high performance are the main characteristics of this product range





*not just valves,
but solutions*



ghibsonvalves.com

Ghibson Italia srl

Via Dozza, 2 40069 Zola Predosa BO Italy

tel +39 051 835711

info@ghibson.it