

Additional ATEX HD safety instructions for High Performance butterfly valves

Ghibson “High Performance” butterfly valves	
Type	“Double eccentric design”
Series	BVHD-BLHD- BVHDR-BLHDR
Size	DN 40-500

	<p>CAUTION: This additional ATEX safety manual <u>must be read carefully before use</u>, and then kept for consultation by the personnel involved in installation and routine and unscheduled maintenance. Such personnel must be competent, meaning made up of people with adequate training, knowledge and working experience to carry out the work entrusted to them correctly and to be aware of and eliminate any hazards.</p> <p>Specifically, they must know the relevant standards, provisions, accident prevention regulations and operating conditions, and have authorisation from the safety officer to carry out the specific work required.</p>
---	--

These supplementary instructions refer to the valves specified and described in greater detail in the catalogues Butterfly Valves – “High Performance” [HD04/19] (available online at the website www.ghibson.it), and are intended to provide all the additional information needed to use Ghibson valves correctly in potentially explosive atmospheres. The safety information contained in these additional ATEX HD operating instructions applies exclusively to butterfly valves. Further risks may arise when they are used in combination with other components (accessories such as actuators, sensors, etc.) or installed in a more complex system.

The installer/operator/end customer is responsible for considering these potential hazards.

First of all, observe the generally applicable safety and accident prevention regulations, as well as the information contained in these ATEX HD operating instructions related to automated valves:

IN FACT, HAND-OPERATED VALVES (with lever or manual gearbox) ARE NOT COVERED by ATEX 2014-34-EU.

WARNING: examine the system specifications before installing the valve on or removing it from the line, or before any other procedure on the piping:

- **make sure that there is no explosive atmosphere.**
- **identify the nature of the fluid being shut off and use appropriate protective clothing and equipment to prevent hazards and/or injuries.**
- **if necessary, make sure that the piping has cooled down properly.**
- **safely cut off the power sources to the actuator,**
- **depressurise the line and flush any fluid from it properly.**
- **to prevent mechanical damage, close the valve by hand before removing it from the line.**



The warranty and liability depend on the terms and conditions contractually agreed with the end customer/installer/agent.

The installer/operator/end customer is the natural or legal person using the butterfly valve, or who provides the instruction for its use. The installer/operator/end customer must ensure that the following requirements are fulfilled:

- ❖ When assembled and connected, the butterfly valve must comply with the relevant directives.
- ❖ Only qualified personnel may have access to work on the butterfly valve.
- ❖ Personnel must have access to the operating instructions, including these additional ATEX instructions, before and while carrying out relevant work, and must follow such instructions.

- ❖ Personnel (operating and maintenance) are therefore informed and trained on all applicable safety and accident prevention regulations, and on safe installation procedures related to butterfly valve operation.
- ❖ These instructions must be clearly understood.
- ❖ Unqualified personnel may not work on butterfly valves.
- ❖ All necessary safety and accident prevention regulations must be observed while installing or carrying out maintenance on butterfly valves.

Contact Ghibson Italia S.r.l. if there are any doubts or training needs.

“INTENDED USE”

The butterfly valves are designed for use in applications for shutting off, regulating and controlling the flow of a “fluid”. The valve complete with its actuator [the **Partly Completed Machinery**] can only perform this function after it has been inserted between the flanges of a piping system, of which it will become part.

The permissible temperature or pressure limits (in relation to the materials, liner material/coating material) are provided on the butterfly valve marking plate as **TS_{min}** and **TS_{max}** (minimum and maximum permissible temperature) and **PS** (maximum permissible pressure).

The materials (liner, body and disc) MUST be compatible with the fluid in terms of corrosion resistance and system operating temperature and pressure, and must be suitable for the environmental conditions at the place of installation.

When installing in places with potentially explosive atmospheres, the following standard environmental conditions are set out in EN 80079-36:

- Ambient temperature from -20°C to +60°C
- Pressure from 80 kPa (0.8 bar) to 110 kPa (1.1 bar)
- Air with a typical oxygen content of 21% v/v.

The installer/operator/end customer must assess any environmental conditions that differ from these.

The installer/operator/end customer must expressly specify the intended type of use. The information provided **must be consistent** with the actual system design data (zone classification and gas and/or dust group).

The operating temperature limits of Ghibson butterfly valves vary, depending on the materials used. The ambient temperature limits ($-50^{\circ}\text{C} \leq T_{\text{ambient}} \leq +80^{\circ}\text{C}$) are greater than those specified in the standard. Note that the standards refer to the fluid temperature except when the specifications explicitly state that the “design temperature” means the ambient temperature T_{ambient} .

The maximum operating temperature (TS_{max}) and the maximum operating pressure (PS) of the butterfly valve [in relation to the **fluid type** (to assess its aggressiveness/compatibility)] are closely linked to the materials chosen by the customer when ordering. The materials of the butterfly valve components must be selected according to the operating/installation conditions and specified in the purchase order.

NEVER EXCEED the fluid pressure PS and temperature range TS_{min} – TS_{max} specified on the plate of each butterfly valve.



The term “INTENDED USE” therefore means full compliance with the specified parameters.

NB: The installer/operator/end customer must also consider that the temperature limit T_{ambient} may be further restricted by the specific actuator used. **CHECK THE RELATIVE DOCUMENTATION**

Butterfly valves that are suitable for use in ATEX classified zones have a second plate in addition to the standard one. For space reasons, this additional plate contains a permitted reduction in the marking (point 11.4 - EN ISO 80079-36:2016) with  **II 2GD** in accordance with ATEX Directive 2014/34/EU, followed by **Ex h X** for the indications required by the EN ISO 80079-36 standard.



For example: with **X** indicates that the user must read and consider these additional ATEX safety instructions, including Annex I, in order to obtain all the information needed to assess the suitability of the valve and its correct use in the specific explosive atmosphere.

Below is the key to understanding the full but generic indications. For this reason, they will be provided again in Annex I for the valve type.

EPT¹⁾ xx ATEX xxxx²⁾

	II 2G	Ex h³⁾	II⁴⁾v⁵⁾	85°C...z°C⁶⁾	(Ty⁷⁾) Gb⁸⁾
	II 2D	Ex h³⁾	III⁹⁾C¹⁰⁾	85°C...z°C⁶⁾	Db¹¹⁾

-50°C ≤ T_{ambient}¹²⁾ ≤ +80°C







CODING KEY

1)	"EPT"- reference to the notified body to which the Technical File related to the ATEX Directive has been submitted.
2)	"xx ATEX xxxx"- Tech. File reference number: 14 ATEX HDBV-2020
3)	"h"- is the symbol used for non-electrical equipment with "c" constructional safety protection in accordance with EN ISO 80079-37:2016.

Ghibson butterfly valves are suitable for use in ATEX 1 and 21 zones (and therefore also 2 and 22) with some restrictions that can be specified with the following symbols:

4)	"II"- indicates the "Explosion group": this symbol is used for equipment that is suitable for explosive gas atmospheres.
5)	<p>"v"- Ghibson valves may be restricted to use with group IIB or IIA gases. The discriminating factor is the thickness of the paint or disc coating, if any:</p> <ul style="list-style-type: none"> - for unpainted valves (stainless steel or bronze-aluminium body) or those with standard painting (60±20 µm thick) and no coating → thickness < 0,2mm → no restrictions → IIC/IIB/IIA indiscriminately - for coated discs or valves with special painting (200 µm ≤ thickness < 2mm) → IIB/IIA restrictions: Group IIC gases such as hydrogen, acetylene, carbon disulphide, etc.) are therefore EXCLUDED. - for thickness ≥ 2mm → only Group IIA gases <p>THE VALVES ARE NEVER SUITABLE FOR FLAMMABLE AND CHEMICALLY UNSTABLE GASES (i.e. flammable gases capable of explosive reactions even without air or oxygen) and HYBRID MIXTURES.</p>
6)	"z°C"- as already explained, the maximum surface temperature of the valve depends on the fluid temperature and environmental conditions. "z" is therefore variable, and its upper limit will depend on the liner or

	on the flat gaskets (gaskets not supplied by Ghibson). See Table 1 below and Annex I.
7)	<p>"Ty"- the maximum surface temperature of the valve depends on the fluid temperature and environmental conditions. Ty is therefore variable, and its upper limit will depend on the liner (T_{liner max}), or on the flat gasket (gaskets not supplied by Ghibson). See Table A and Annex I.</p> <p>Conversely, the minimum temperature is only given on the standard plate. The PED refers to the fluid temperature when it states that the choice of materials depends on their mechanical properties: all materials used for HD can be used for temperatures < -10°C, but the Charpy test must be performed (Resil. ≥ 27J at T_{min required}) otherwise the limit remains -10°C.</p>
8)	<p>"Gb"- indicates the "EPL - Equipment Protection Level" of Ghibson valves in relation to gaseous atmospheres. It indicates that they are suitable for Zone 1 and therefore also Zone 2 (inside/outside).</p> <p>They cannot be used in Zone 0.</p>
9)	<p>"III"- indicates the "Explosion group": this symbol is used for equipment that is suitable for explosive dust atmospheres.</p>
10)	<p>"C"- indicates that Ghibson valves can also be used with conductive dusts.</p>
11)	<p>"Db"- indicates the "EPL - Equipment Protection Level" of Ghibson valves in relation to dust atmospheres.</p> <p>It indicates that they are suitable for Zone 21 and therefore also Zone 22 (inside/outside).</p> <p>They cannot be used in Zone 20.</p>
12)	<p>"T_{ambient}"-: ambient temperature range.</p> <ul style="list-style-type: none"> Some system specifications require a "low design temperature" explicitly due to the minimum ambient temperature (T_{ambient min.}), regardless of the fluid temperature. In this case, TS_{min} (generally the worst case from the metal used and the liner elastomer) must be: TS_{min} ≤ T_{ambient min.} The maximum ambient temperature (T_{ambient max.}) is specified as 80°C for the valves. <p>THE ACTUATOR MAY LIMIT THIS RANGE</p>

<p>PROHIBITION: DO NOT USE Ghibson butterfly valves in <u>Zone 0 and Zone 20</u> classified explosive atmospheres, either inside or outside.</p>	
	<p>PROHIBITION: DO NOT use Ghibson butterfly valves with:</p> <ul style="list-style-type: none"> • <u>hybrid mixtures</u> (hybrid mixtures are mixtures of air and flammable substances in different material states). • <u>chemically unstable gases</u> (flammable gases capable of explosive reactions even without air or oxygen)
<p>PROHIBITION: DO NOT use Ghibson butterfly valves BV-BLHD with special paint thicknesses when:</p> <ul style="list-style-type: none"> • thickness $\geq 0,2$ mm and the explosive atmosphere contains Group IIC gases. • thickness ≥ 2 mm and the explosive atmosphere contains Group IIB gases. 	
	<p>WARNING: The installer/user is responsible for ensuring strict compliance with the system specifications and for taking measures or using devices to prevent adiabatic compression and shock waves.</p>
<p>WARNING: The user must assess whether the fluid/liquid being shut off can give rise to electrostatic charges in the liner or in the piping if it is made of plastic.</p>	
	<p>WARNING: The installer/user will have to assess whether the intercepted fluid is compatible with the flat gaskets (not supplied by Ghibson Italia S.r.l.) inserted between the valve and the flanges and</p>

	whether these introduce limitations to the service/use temperature range
--	---

WARNING: The installer/user must make a new risk assessment in the event that a subsequent coat of paint is applied to the valve/pipe with reference to the classification of gas groups present in the explosive atmosphere.



CAUTION: as also indicated in the ATEX guidelines, the installer must ensure that the components, initially compliant, are still compliant when they are put into service. For this reason he must carefully follow all the installation instructions of the various manufacturers. The user must demand and verify that these instructions have been followed.



Table 1 – GAS - Maximum surface temperatures and T_{fluid}

LINER	$T_{liner\ max}$		T - classe	$T_{Surf,max}$ in relation to T_{fluid}
RTFE	230°	T6...T2	T6	85°C
			T5	100°C
			T4	135°C
			T3	200°C
			T2	230°C
INCONEL	450°	T6...T1	T6	85°C
			T5	100°C
			T4	135°C
			T3	200°C
			T2	300°C
			T1	450°C

Using valves at temperatures lower than TS_{max} will therefore result in a lower temperature class, making the valve suitable for more "critical" explosive atmospheres.

For example, Table 1 shows that an A216 WCB valve (TS_{max} 425°C) with an RTFE liner (TS_{max} 230°C) will have $TS_{max} = 230°C$, which corresponds to temperature class T2.

However, as already said, the surface temperature of the valve is due exclusively to the fluid (for example T_{max} 90°C) and environmental conditions (T_{max} 80°C).

These conditions result in a temperature class of T5, meaning it can also be used with a more demanding atmosphere.

TEMPERATURE CLASSES (GAS)

Maximum equipment surface temperature achievable for potential use in an explosive gas atmosphere.



WARNING: gases may have different ignition temperatures, even though they belong to the same group.
Some examples:

T-classe	Massima temperatura Superficiale	Minima temperatura di accensione del gas
T1	450 °C	>450 °C
T2	300 °C	>300 - ≤450 °C
T3	200 °C	>200 - ≤300 °C
T4	135 °C	>135 - ≤200 °C
T5	100 °C	>100 - ≤135 °C
T6	85 °C	>85 - ≤100 °C

Gruppo	Tipo GAS	Temperatura di accensione
A	Acetone	540 °C
	Acido acetico	485 °C
	Ammoniaca	630 °C
	Etano	515 °C
	Cloruro di metilene	556 °C
	Metano (CH ₄)	595 °C
	Ossido di carbonio	605 °C
	Propano	470 °C
	n-butano	365 °C
	n-butile	370 °C
	Idrogeno solforato	270 °C
	n-esano	240 °C
	Acetaldeide	140 °C
Etere etilico	170 °C	
Nitrito di etile	90 °C	
B	Etilene	425 °C
	Ossido di etile	429 - 440 °C
C	Acetilene (C ₂ H ₂)	305 °C
	Bisolfuro di carbonio	102 °C
	Idrogeno (H ₂)	560 °C

Table 2 – DUST - Maximum surface temperatures and T_{fluid}

LINER	“Temperature Range” generic	T_{Surf}-max in relation to T_{fluid}
RTFE	85°C...230°C	230°C
INCONEL	85°C...450°C	450°C





Note:

In its deposited form (layers), dust has a different ignition temperature than in its mixed form (cloud).

The permissible surface temperature for those parts of systems, equipment and components exposed to dust is determined by introducing a safety factor [subtracting 75 K (T_{perm L} = T_{min L} - 75 K) from the value determined for the dust layer, and multiplying the value determined for the dust cloud by 2/3 (T_{perm C} = 2 / 3T_{min C}). The smaller of the two values calculated in this way is the lowest permissible surface temperature of the equipment].

No temperature classes have been defined for dusts. Comprehensive tables like the one below are available, but they are UNOFFICIAL.

LINER	T_{liner max} permissible service	DUSTS																																																		
		Some examples of dust ignition temperatures (varies by consistency and nature)																																																		
RTFE	+230°C	<table border="1"> <thead> <tr> <th>Polveri</th> <th>Nubi</th> <th>Spessore di 5 mm</th> </tr> </thead> <tbody> <tr><td>Alluminio</td><td>560 °C</td><td>>450 °C</td></tr> <tr><td>Carbone di legna</td><td>520 °C</td><td>320 °C</td></tr> <tr><td>Polvere di carbone</td><td>380 °C</td><td>225 °C</td></tr> <tr><td>Cacao</td><td>590 °C</td><td>250 °C</td></tr> <tr><td>Fondi di caffè</td><td>580 °C</td><td>290 °C</td></tr> <tr><td>Mais</td><td>530 °C</td><td>460 °C</td></tr> <tr><td>Cellulosa metilica</td><td>420 °C</td><td>320 °C</td></tr> <tr><td>Resina fenolica</td><td>530 °C</td><td>>450 °C</td></tr> <tr><td>Polietilene</td><td>440 °C</td><td>fusioni</td></tr> <tr><td>PVC</td><td>700 °C</td><td>>450 °C</td></tr> <tr><td>Zucchero</td><td>490 °C</td><td>460 °C</td></tr> <tr><td>Fuliggine</td><td>810 °C</td><td>570 °C</td></tr> <tr><td>Amido</td><td>460 °C</td><td>435 °C</td></tr> <tr><td>Toner</td><td>520 °C</td><td>fusioni</td></tr> <tr><td>Frumento</td><td>510 °C</td><td>300 °C</td></tr> </tbody> </table>			Polveri	Nubi	Spessore di 5 mm	Alluminio	560 °C	>450 °C	Carbone di legna	520 °C	320 °C	Polvere di carbone	380 °C	225 °C	Cacao	590 °C	250 °C	Fondi di caffè	580 °C	290 °C	Mais	530 °C	460 °C	Cellulosa metilica	420 °C	320 °C	Resina fenolica	530 °C	>450 °C	Polietilene	440 °C	fusioni	PVC	700 °C	>450 °C	Zucchero	490 °C	460 °C	Fuliggine	810 °C	570 °C	Amido	460 °C	435 °C	Toner	520 °C	fusioni	Frumento	510 °C	300 °C
Polveri	Nubi	Spessore di 5 mm																																																		
Alluminio	560 °C	>450 °C																																																		
Carbone di legna	520 °C	320 °C																																																		
Polvere di carbone	380 °C	225 °C																																																		
Cacao	590 °C	250 °C																																																		
Fondi di caffè	580 °C	290 °C																																																		
Mais	530 °C	460 °C																																																		
Cellulosa metilica	420 °C	320 °C																																																		
Resina fenolica	530 °C	>450 °C																																																		
Polietilene	440 °C	fusioni																																																		
PVC	700 °C	>450 °C																																																		
Zucchero	490 °C	460 °C																																																		
Fuliggine	810 °C	570 °C																																																		
Amido	460 °C	435 °C																																																		
Toner	520 °C	fusioni																																																		
Frumento	510 °C	300 °C																																																		
INCONEL	+450°C																																																			
Gr. IIIA Combustible fibers Gr. IIIB Non-conductive but combustible dusts Gr. IIIC conductive and combustible dusts																																																				

<p>WARNING: The operator/end customer must assess the above risks.</p>	
	<p>PROHIBITION: never exceed the service temperature limits specified for butterfly valves. Monitor the temperature if the process is critical (if the valve must work close to one of the limits)</p>
	<p>CAUTION: It is clear that the ATEX Directive only considers valves that are <u>ACTUATED</u> [*] and are therefore operated by a pneumatic, hydraulic or electric actuator. <u>This means that the usage restrictions applied by the installer/operator/end customer must be based on the worst-case data plate values from the valve and actuator expressly chosen/used.</u></p> <p>[*] ATEX Directive 2014/34/EU does NOT cover hand-operated valves.</p>
<p>WARNING: all accessories used to complete the installation (specifically with an electric actuator that needs cables, cable glands, etc.) must also be suitable for installation in classified zones, and the installer/operator/end customer must consider whether these accessories will introduce usage restrictions.</p>	
	<p>CAUTION: The safety regulations applicable to butterfly valves, control systems and actuators are the same as those for the piping system in which they are installed.</p>

The valve complete with actuator (partly completed machinery) must be installed in accordance with the procedures below and the recommendations in the following documents:

- Check the technical documentation for the system in which the valve will be installed in order to assess its suitability in terms of safety and performance.
- Check that the butterfly valve is suitable for the explosive atmosphere.
- To install, operate and maintain the valve correctly, follow the instructions in the manual for the "bare axis" valve, supplied with each valve.
- Follow these additional ATEX safety instructions when installing in an explosive atmosphere.
- Follow the instructions in the specific manual provided by the actuator manufacturer (the actuator may already be fitted on the valve).

As mentioned, if there is an actuator, consider the electrical and/or pneumatic and/or hydraulic supply (voltage/frequency of motors or solenoids, air or hydraulic fluid pressure and flow rate) and other installation conditions, which can be found on the actuator plate and/or in its installation and maintenance instructions.



The system design must eliminate hazards arising from these energy sources by providing safe cut-off devices. **If there is a compressed air supply, make sure that it does not contain components or particles that could increase the explosion risk, and monitor its temperature.**

The specialist installation personnel must have technical and regulatory training. When installing electrical cables, for example, they must check that the voltage and frequency matches those on the plate. This is important to eliminate the risk of eddy currents or potential differences between system devices causing electrocution or igniting explosive atmospheres.

Before any disassembly work, always disconnect external power sources (electrical, pneumatic, hydraulic), following the actuator service instructions and, where necessary, allowing sufficient time to ensure safe conditions (e.g. to let a pipe cool down).

For actuators with energy storage (e.g. springs), take great care and strictly follow the service instruction to avert hazards related stored energy (the springs themselves in the example).

The operator/end customer is responsible for assessing the site-specific risks and adding layout instructions where applicable.

<p>PROHIBITION: any change in configuration or use other than that specified in the standard operating instructions and these additional ATEX instructions (failure to comply with the "Intended Use") is considered improper and unintended use of the butterfly valve! This constitutes, at least, an act of gross negligence and Ghibson Italia S.r.l. shall not be held liable for damage arising from such use.</p>	
	<p>PROHIBITION: do not carry out any modifications without consulting the Ghibson Engineering Department. Such modifications may introduce hazards for both the installation personnel and the end user, and may involve the system and the environment. For this reason, unauthorised modifications shall be considered tampering, and will therefore immediately annul the statutory guarantee and automatically relieve Ghibson Italia S.r.l. of any liability.</p>

- ❖ Before installation, make sure that the fluid is compatible with the valve material (both chemically and in terms of temperature limits) and with the potentially explosive atmosphere.
- ❖ Before installation, make sure that the fluid is compatible (both chemically and in terms of temperature limits) with the flat gasket material (not supplied by Ghibson Italia S.r.l. but necessary for the installation between the valve and the pipe flanges). These flat

seals must be also be compatible with the potentially explosive atmosphere.

PROHIBITION: in explosive atmospheres, the piping can only carry “fluids/dust clouds” that are not subject to electrostatic charge build-up: the “fluid/dust cloud” specific contact resistance must be less than $10^8 \Omega$ (Ohm).



- ❖ Visually inspect the liner to ensure it is in good condition since the seal is guaranteed by the interference between the disc and the liner.
- ❖ Plan scheduled inspections/maintenance to check the changes in liner thickness as its wear depends on valve operation. At the same time check the flat gaskets
- ❖ As for a “Safe Area” installation, check the piping connection flanges and clean them if necessary.
- ❖ Check that the valve and piping are properly aligned. The piping must be well supported to prevent mechanical stress and vibration.
- ❖ Since foreign objects such as pieces of metal in the piping could lead to the hazard of igniting an internal explosive atmosphere, they must be prevented upstream with a very high level of reliability.

WARNING: the owner/operator must assess this risk as it is entirely related to operating circumstances.

The valve (IP65 min.) does not allow foreign objects to enter the piping except due to the installer’s negligence during installation.



- ❖ As already stated, the paint and disc coating thicknesses are factors that restrict the use of Ghibson valves. With increased thicknesses of paint or disc coating, the use of Ghibson valves is limited to group IIB gases or even to group IIA only. Such special solutions must therefore be agreed in advance in order to avoid introducing additional risks that were not initially assessed.

- ❖ Do not use compressed air to clean layers of dust deposited on the valve or in general on the piping as blowing could create dust vortices that form an explosive atmosphere.
- ❖ Increase the cleaning frequency if the dust deposits tend to be very substantial.

	<p>PROHIBITION: do not allow dust deposits to become more than 1 mm thick. Processes that involve creating high electrostatic charges are not permitted in outdoor environments.</p>
---	--

- ❖ Remove dust layers regularly to prevent ignition and to ensure the butterfly valve can dissipate heat properly (where applicable) to the surrounding environment.
- ❖ Regardless of the installation type (safe area or classified area), carry out both visual and functional checks regularly to ensure that the disc moves smoothly and there is no seepage in the closed position.

Valve and actuator installation information

<p>WARNING: The installer must be qualified to install pneumatic and/or hydraulic and/or electrical devices and know the national regulations to be observed.</p>	
--	---

The operator/end customer shall provide the installer with all the documents from the individual manufacturers, so that all three “players” can assess the suitability of the components for use in the specific potentially explosive atmosphere.

- The actuators must not exceed the torque limit of the butterfly valve or must be able to stop (torque limiters) if this limit is exceeded.
- Choose actuators that ensure the valve moves with a peripheral speed not exceeding 1 m/s.

- Make sure there is good electrical conductivity between the valve, the piping and the earthing system (equipotential) also using the dedicated connection point (M6x1 hole) in the lower valve plug.

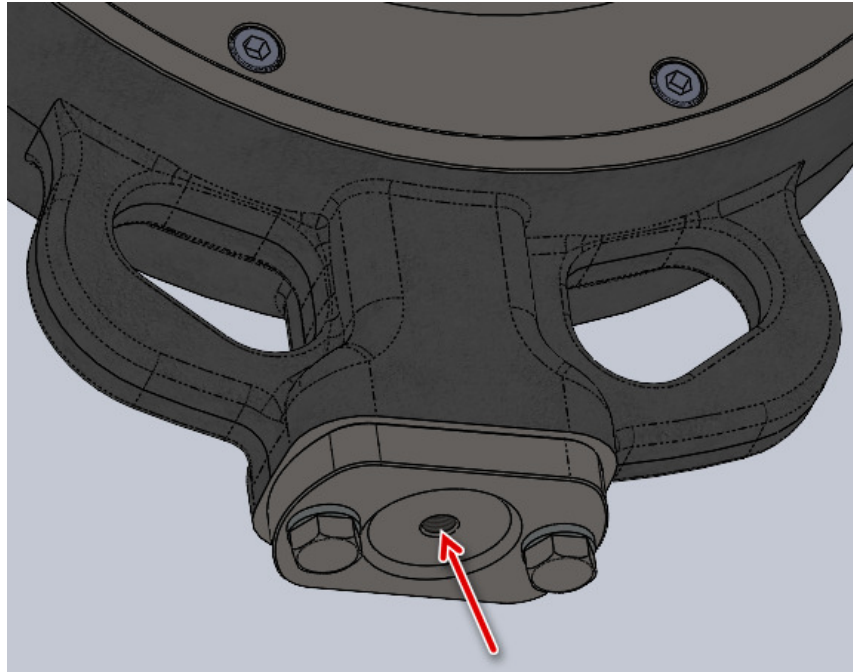

- For electric actuators/accessories (individually compliant with 34/2014/EU), the properly qualified installer must:
- Connect the actuator, accessories and valve properly to the earthing system.
 - Test the earth resistance of the connections made.
- The energy sources (pneumatic, hydraulic and electrical) must have suitable cut-off devices that can be locked by the installer/maintenance technician to prevent unintentional/unwanted actuator movements.
 - Check the operation of each valve/actuator after the first installation.



PROHIBITION: Do not put the valve and actuator into service before the final system/machine in which it is incorporated has been declared compliant with all relevant directives.

It is conceivable that a user could retrofit a manual valve with an actuator:

WARNING/HAZARD: in an application requiring installation in an ATEX classified zone, a manual valve can be retrofitted with an actuator, but it requires a complex analysis of the resulting risks regardless of whether the valve and actuator are individually suitable for the specific potentially explosive atmosphere.



- ✓ first of all, analyse the valve data sheet, especially the torque specified by the manufacturer for the application, and overdimension it with a reasonable factor without exaggerating. **Consult the manufacturer for further information.**
- ✓ assess the operating limits resulting from the valve and actuator combination. The “worst case” will determine the possible usage conditions of the assembly and whether it is suitable for use or not.



CAUTION: by convention, closure normally occurs with clockwise rotation and, unless otherwise specified, the factory normally fits the actuator in parallel with the valve body.

The installation and maintenance instructions for the partly completed machinery are based on these conventions.

Before installing valve in or removing from the line, or before carrying out any disassembly, consider these characteristics and establish the disc position (visual indicator on the actuator or on the limit switch box, if any).

If the valve is in the “bare axis” configuration because the actuator has already been removed, establish its position using the “notch” (mechanical

machining on the pivot) at the top end of the pivot, which is parallel to the disc faces.

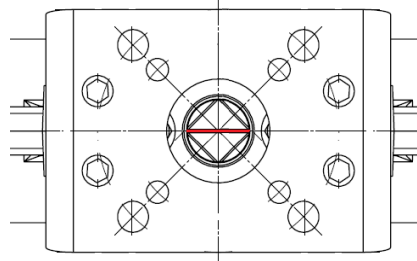

For valves DN \geq 200 refer also to the (red) key.

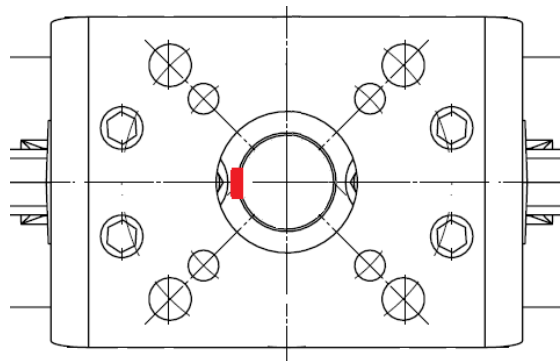

ANNEX I

Procedure for identifying the full ATEX marking, which is not provided on the valve for space reasons.

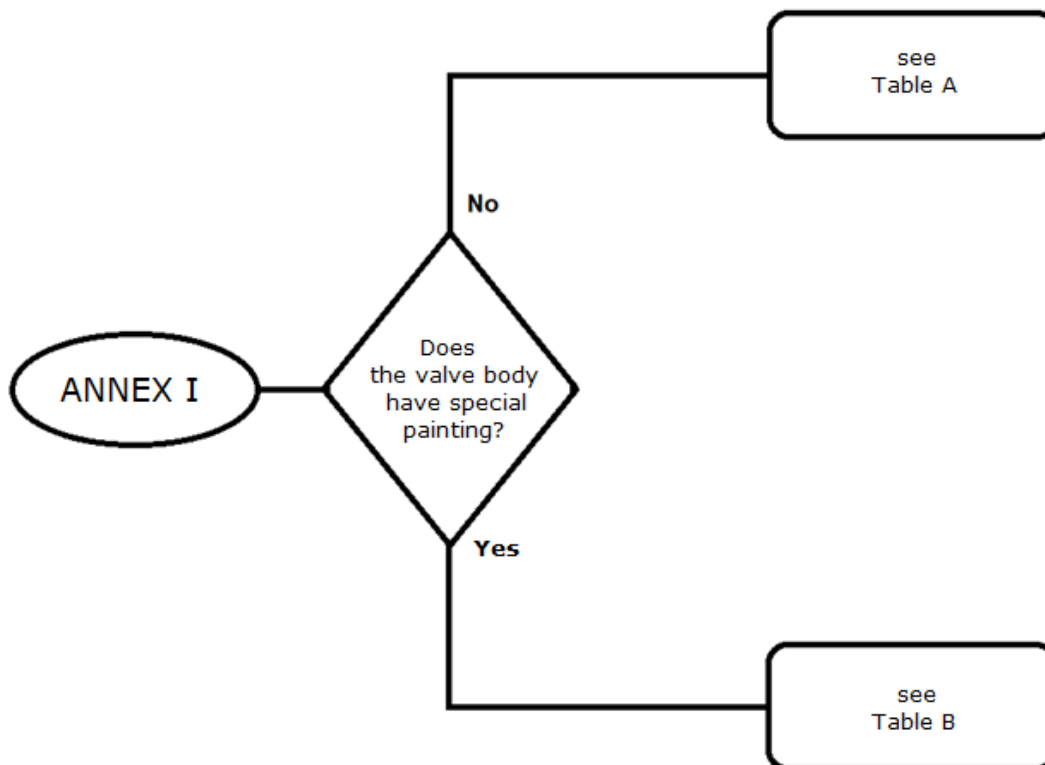



Once the column has been identified, just select the line that corresponds to the liner fitted in the valve to find the full indications with the possible suitability limits.

In very rare cases, generally due to the application of coats of paint after installation, **if the thickness were to be ≥ 2 mm it would be forbidden to use the valves in explosive atmospheres with the presence of gases of group IIC and IIB:**

suitability for Group IIA gas only ↔ Ex II 2G Ex h IIA 85°C...

Table A – Full marking – **with or without standard painting** (↔ also suitable for Gr. **IIC** gases)

LINER	T _{liner max}	T - classe	T Surf. ^{max} a seconda di TS _{max} fluido	MARKING
RTFE	230°	T6	85°C	 II 2G Ex h IIC 85°C...230°C (T2) Gb II 2D Ex h IIIC 85°C...230°C Db -50°C ≤ T _{amb.} ≤ +80°C
		T5	100°C	
		T4	135°C	
		T3	200°C	
		T2	230°C	
INCONEL	450°	T6	85°C	 II 2G Ex h IIC 85°C... 425°C (T1) Gb II 2D Ex h IIIC 85°C... 425°C Db -50°C ≤ T _{amb.} ≤ +80°C [*] This limit depends on the body/disc material
		T5	100°C	
		T4	135°C	
		T3	200°C	
		T2	300°C	
		T1	425÷450°C [*]	

NOTE: Remember that the maximum surface temperature of the valve is determined by the temperature of the fluid conveyed and by the environmental conditions. For this reason the maximum temperature is indicated as a range [EN ISO 80079-36: 2016 point 11.2. f)] and not a definite value.







<p>PROHIBITION: DO NOT USE Ghibson butterfly valves in <u>Zone 0</u> and <u>Zone 20</u> classified explosive atmospheres, neither inside nor outside.</p>	
	<p>PROHIBITION: DO NOT USE Ghibson butterfly valves with:</p> <ul style="list-style-type: none"> • <u>hybrid mixtures</u> (hybrid mixtures are mixtures of air and flammable substances in different material states). • <u>chemically unstable gases (flammable gases capable of explosive reactions even without air or oxygen)</u>

Table B – Full marking – with $[0,2 \leq th(mm) < 2]$ painting ↔ suitable for Gr. IIB (and IIA) gases only

GUARNIZIONE	T _{liner max}	T - classe	T Surf. ^{max} a seconda di TS _{max} fluido	MARCATURA
RTFE	230°	T6	85°C	 II 2G Ex h IIB 85°C...230°C (T2) Gb II 2D Ex h IIIC 85°C...230°C Db -50°C ≤ T _{amb.} ≤ +80°C
		T5	100°C	
		T4	135°C	
		T3	200°C	
		T2	230°C	
INCONEL	450°	T6	85°C	 II 2G Ex h IIB 85°C...425°C (T1) Gb II 2D Ex h IIIC 85°C...425°C Db -50°C ≤ T _{amb.} ≤ +80°C [*] Questo limite varia e dipende dal materiale del corpo/disco
		T5	100°C	
		T4	135°C	
		T3	200°C	
		T2	300°C	
		T1	425÷450°C [*]	



PROHIBITION: In addition, the prohibitions mentioned previously, **DO NOT use** Ghibson butterfly valves with special painting (increased thickness) and/or a coated disc, being therefore:

 II 2G Ex h IIB 85°C...

when the explosive atmosphere contains **Group IIC** gases (e.g. hydrogen, acetylene, carbon disulphide, etc.).

Rarely with $th(mm) \geq 2$ painting ↔ suitable for Gr. IIA gases ONLY  II 2G Ex h IIA 85°C...

WARNING/HAZARD: [*] in the case of an Inconel metal seal, the upper limit for the operating temperature derives from the worst case between the limit due to Inconel itself [450 ° C] and the limit imposed by the material of the valve body and disc.

To give a clarifying example in the case of a WCB body this material limits the valve operating temperature (TS_{max}) to 425°C.



Example

The standard valve plate, used previously, identifies a valve with CF8M (stainless steel) body/disc and RTFE liner:



- BVHD series wafer type
- DN 250 size
- PN25 flanges
- PS 25 bar (imposed by the BxHD series)
- TS_{min} -50°C {imposed by the CF8M body [if Charpy Test is ok (>27J)] and therefore the fluid}
- TS_{max} +230°C (imposed by the RTFE liner and therefore the fluid)

Moreover, since it is intended to operate in a classified zone, it also bears a second plate with simplified marking like the adjacent one, which refers to these additional ATEX HD safety instructions.



Assuming that it has been ordered, obviously for a suitable fluid that is compatible with the both liner/material and the temperature range, being the CF8M WITHOUT painting (which implies suitability for all three gas groups IIA, IIB and IIC), refer to **Table A**.

The "RTFE" line contains:

Table A – Full marking – with or without standard painting.

LINER	T _{liner max}	T - classe	T _{Surf,max} a seconda di TS _{max} fluido	MARKING
RTFE	230°	T6	85°C	II 2G Ex h IIC 85°C...230°C (T2) Gb II 2D Ex h IIIC 85°C...230°C Db -50°C ≤ T _{amb} ≤ +80°C
		T5	100°C	
		T4	135°C	
		T3	200°C	
		T2	230°C	

So, the full classification is:



II 2G Ex h IIB 85°C...230°C (T2) Gb
II 2D Ex h IIIC 85°C...230°C Db
 -50°C ≤ T_{ambient} ≤ +80°C

**note the indication
as a range**

Repeating once again, the surface temperature of the valve is due exclusively to the fluid (for example T_{\max} 175°C) and environmental conditions ($T_{a_{\max}}$ 80°C).

These conditions result in a temperature class of T3, meaning the valve can also be used with a more demanding atmosphere.



WARNING/HAZARD: as we already know, a hand-operated valve is NOT covered by the ATEX Directive.

Only valves combined with an actuator have to comply with the Directive.

As amply demonstrated, the valve plate data must be compared with the actuator plate data to assess the suitability of the assembly for the specific explosive atmosphere that may occur in the system. The "worst case" values must therefore also fulfil the parameters imposed by the zone classification.

The installer/end user is responsible for ensuring that the equipment used strictly complies with the system specifications and restrictions. The installer/end user must check the assembly before it is put into service.

WARNING / HAZARD : the user will have to assess whether the fluid intercepted can cause electrostatic charge phenomena on the gasket of valve. As indicated in §38 of the ATEX Guidelines, these "polymeric parts could become charged, but this is no different from plastic pipes. Given that it is clear that the latter is outside of the scope of Directive 2014/34 / EU," that same applies to the gasket: **this possible phenomenon is therefore only reported to the installer/end user.**

